

Logic gate truth table generator: the development of hardware-based educational simulator for conversion of combinatorial circuit to truth table

Mohd Syazwan Syafiq Sulaiman¹, Muhamad Amir Aiman Azuri¹, Muhammad Izzat Zakwan Mohd Zabidi^{2*}, Amar Faiz Zainal Abidin², Arman Hadi Azahar², Rahaini Mohd Said², Nur Aiman Hanis Hasim³, Kamaru Adzha Kadiran³, Mohd Mohd Safirin Karis⁴

¹ Faculty of Electrical Engineering, Universiti Teknikal Malaysia Melaka,
76100 Durian Tunggal, Melaka, Malaysia

² Faculty of Electrical & Electronic Engineering Technology, Universiti Teknikal Malaysia Melaka,
76100 Durian Tunggal, Melaka, Malaysia

³ Faculty of Mechanical & Manufacturing Engineering Technology, Universiti Teknikal Malaysia Melaka,
76100 Durian Tunggal, Melaka, Malaysia

⁴ Faculty of Electrical Engineering, Universiti Teknologi MARA Cawangan Johor, Kampus Pasir Gudang,
Jalan Purnama, Bandar Seri Alam, 81750 Masai, Johor Darul Takzim, Malaysia

*Corresponding e-mail: izzat.zakwan@utem.edu.my

Keywords: educational kit; digital electronics; logic gate circuit

ABSTRACT –Digital Electronic is one of the topics related to the conversion of the combinatorial logic gate circuit to the logic gate's truth table. Currently, there are a few types of the software-based simulator to simulate this conversion, where it's deemed unsuitable for secondary school students as it only focuses on the cognitive element. Therefore, the aim of this project was to produce an educational logic gate simulator that involved the cognitive and psychomotor elements which are seen as bridging between theoretical and laboratory session. The educational kit is tested in a different scenario in order to validate the simulation obtained.

1. INTRODUCTION

Logic gate theory is the gist of Digital Electronic subject which a core subject of Electronic and Electrical Engineering students at tertiary level. In order to give better exposure to secondary level education, the basic logic gate concept has been introduced as part of Sijil Pelajaran Malaysia's (SPM, the equivalent of United Kingdom's O-Level) Physics subject. Thus, it can be foreseen the future prospect of truth table being introduced in the SPM's Physics. Based on this anticipation, the available teaching aid is not interactive, simple and cost-effective to help teachers in the teaching and learning process. Thus, this project aims to solve the three problems by producing an educational kit simulator that able to convert the three inputs and one output combinatorial circuit to the truth table.

The publication trend of electronic hardware-based educational kit is an increasing trend. Faseh et al. proposed an inexpensive version of the electronic board kit for secondary level education that simulates Programmable Logic Controller's (PLC) Mnemonic Code [1]. Zakaria proposed the development of the portable quiz board that tests student knowledge on the second-order system's transient response which Control Principles [2]. Yaacob et al. proposed an educational kit that test student knowledge of C Programming by using

Flowchart block [3]. Recently, M. F. M. A. Halim et al. developed an unsupervised educational quiz board that tests secondary student knowledge on combinatorial resistors configuration [4].

2. METHODOLOGY

The proposed educational kit has a size of 50 cm of length, 30 cm of width and 15 cm of height. The material used in PVC plastic because it's durable yet light with weight only around 500 gm. Then, the cost of the proposed educational kit is estimated at less than RM150, where, there is an affordable price for the secondary school students. Figure 1 illustrates the physical layout of the proposed kit. The top part of the educational kit is the area where the student will do the wiring required for the combinatorial logic circuit required. The bottom area is where a matrix of Red-Green Light Emitted Diodes (RG LEDs) which used to represent the truth table.



Figure 1 Hardware layout.

Figure 2 shows the schematic diagram of the proposed educational kit where it consists of one Arduino Mega, 32 two shift registers, one push button, one buzzer, and five different types of logic gates integrated circuits (ICs).

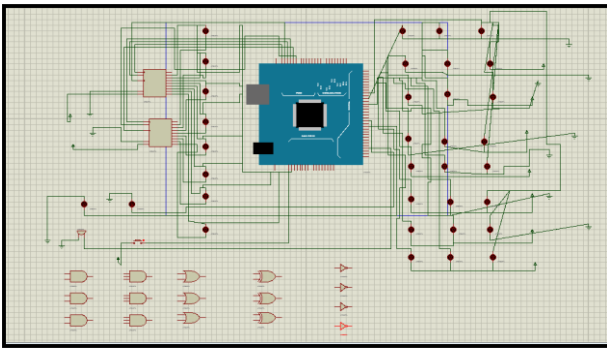

Figure 2 Schematic diagram.

Arduino Mega is used as the brain of the kit which coordinates all the other components. The push-button is used as feedback to Arduino where when the user presses the push button, Arduino will inject different combination On (or 1) state and Low (or 0) state at the inputs (A, B, and C) which will pass through the gates based on the connection done by the user. The output (Y) of the connection will be feed into Arduino which can either be in On or Off state. The truth table is represented by 32 RG LEDs where red represents the Off state (or 0 state) and Green represents the On state (or 1 state). The shift register is used to coordinates the RG LEDs which reduce the number of pins required for LEDs connection from 64 digital pins to eight pins only.

3. RESULTS AND DISCUSSION

The proposed kit has been tested for all 256 combinations where the educational kit performs well as expected. Following are one of the examples used to illustrate the outcome produced by the kit. Given the combinatorial logic gate as in Figure 3, the expected connection is done at the kit and truth table produced by the kit as in Figure 4. The truth table of the circuit as tabulated in Table 1.

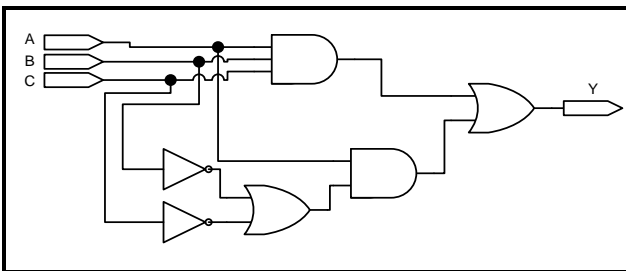

Figure 3 Schematic of $Y = ABC + A(\bar{B} + \bar{C})$.



Figure 4 Educational kit connection.

Table 1 Truth table of $Y = ABC + A(\bar{B} + \bar{C})$.

C	B	A	Expected Output Y	Actual Output Y
0	0	0	0	0
0	0	1	1	1
0	1	0	1	1
0	1	1	1	1
1	0	0	1	1
1	0	1	1	1
1	1	0	1	1
1	1	1	1	1

The educational kit has been verified to pass all the functionality test. This consists of running all 256 possible solutions.

4. CONCLUSIONS

This project highlights the development of an educational kit that able to translate the combinatorial logic circuit to its respective truth table. The proposed kit has been tested with all possible scenario and produce the expected result.

REFERENCES

- [1] Faseh, M. H. A. H. A. M., Ismail, F. N., Majid, M. A., Abidin, A. F. Z., Yusoff, Z. M., Rifin, R., Hasan, K. K., Ali, N. M., & Rizman, Z. I. (2018). E-PLC: The Development of a Programmable Logic Controller Trainer that Translates Mnemonic Codes to Hardware Simulation. *Journal of Fundamental and Applied Sciences*, 10 (2S), 499-513.
- [2] Zakaria, M. F. Z. M., Aziz, S. A. C., Abidin, A. F. Z., Adip, M. A., Rahim, N., & Hassan, W. H. W. (2018). The Development of an Electronic Educational Quiz Board that Test Student Knowledge on Control Principle's Second Order Transient Response by Using DC Motor Speed Control as Application. *ARNP Journal of Engineering and Applied Sciences*, 13 (13), 4079-4082.
- [3] Yaacob, M. R., Diah, A. I. M., Abidin, A. F. Z., Kadiran, K. A., Mustapa, R. F., Abdullah, M., Ismail, M. I., & Zaiton, S. N. A. H. (2018). e-Flowchart: An Electronic Educational Quiz Board that Test Student Knowledge on C Programming Concept using Flowchart Command. *ARNP Journal of Engineering and Applied Sciences*, 13 (23), 9081-9085.
- [4] Halim, M. F. M. A., Nor, A. M. M., Badari, A. A. B., Abidin, A. F. Z., Kadiran, K. A., Adam, A., Mohamad, S. H., & Harun, M. H. (2019). Reseducational Kit: The Development Of An Electronic Quiz Board That Test Engineering Students Knowledge on Resistors Concept in Electrical Circuit. *International Journal of Recent Technology and Engineering*, 8 (1), 202-207.